

OPERABLE WALLS
Panelfold®
Moduflex®
 SERIES 500
 Paired Panels
 Model 520

PRODUCT BRIEF

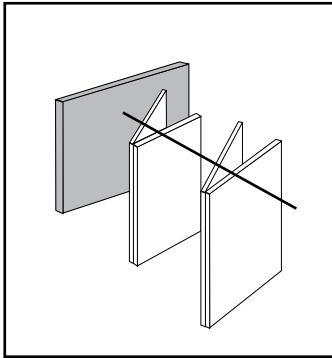

OPERATING FEATURES.
Moduflex Model 520 panels, hinged in groups of two, each top supported by radial type, steel ball-bearing wheels, may be conveniently manually operated and "center" stacked. Heights to 18' (5486).

ACOUSTICAL PERFORMANCE.
Moduflex Series 500 operable walls have attained ratings of STC 52 and STC 50.

PANEL FINISHES. A full range of vinyl, panel fabric, wall carpet and Customer's Own Materials is offered.

TYPES OF CLOSURES
 See pages 2,3 and 4 for details.

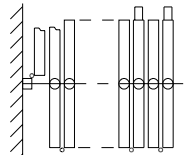

Single Panel used with odd numbered panel openings.

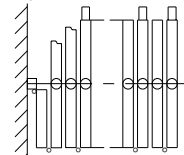

Bi-Fold Panels used with even numbered panel openings.

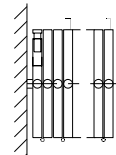

Expandable Panel - Seal to Wall used with even numbered panel openings.

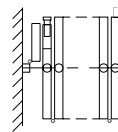

Single Panel With Expandable Panel - used with odd numbered panel openings.

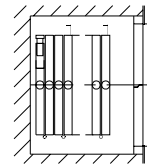

Expandable Panel - Seal to Pocket Door used with even numbered panel openings.

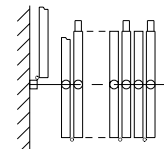

Communicating Panel used with odd numbered panel openings for egress.

OPTIONS AND ACCESSORIES

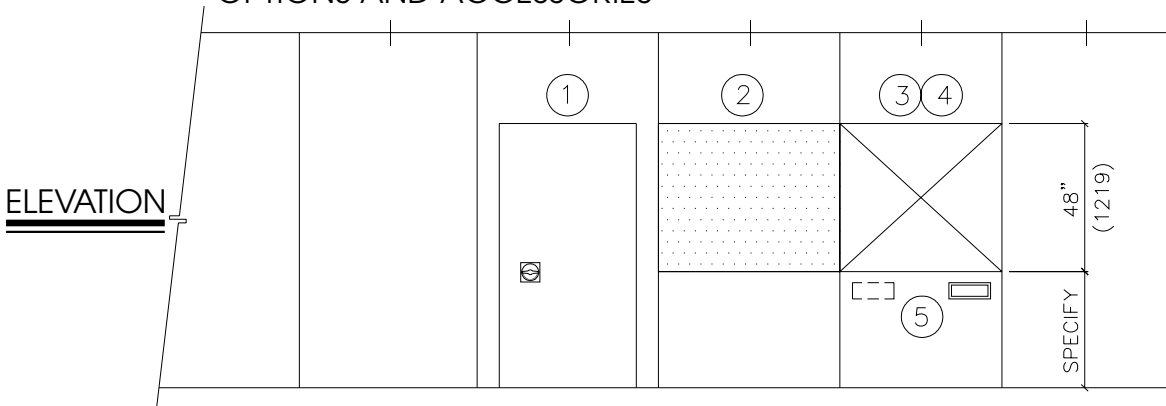

OPTIONS SPECIFICATIONS
 See page 8 for Product Specifications

- ① SINGLE PASS DOORS where indicated shall be nominally (specify: 3'0" (914); or 2'8" (813)) wide by (specify: 6'8" (2032); or 7'0" (2134)) high. Doors shall be manufactured of the same materials and thickness as the panels and be equipped with butt-type hinges and positive latches with drop cup and ring pulls. Options: deadbolt locks; self illuminated exit signs; hydraulic door closers; A.D.A. compliant friction roller latch with flush pulls.
- ② TACKBOARDS where indicated shall be nominally (specify: 48" (1219)) high; or full panel height). Tackboards shall consist of 1/4" (6) cork surfaced with minimum 30oz per lineal yard Type II Fabrictex vinyl fabric (color to be selected from manufacturer's standards) and bronze trimmed.
- ③ CHALKBOARDS where indicated shall be nominally (specify: 48" (1219) high; or full panel height). Chalkboards shall be chalkable porcelain enameled steel (color to be selected from manufacturer's standards) and bronze trimmed.
- ④ MARKERBOARDS where indicated shall be nominally (specify: 48" (1219) high; or full panel height) and be of suitable non-porous surfaced porcelain enameled steel for application of write-on, wipe-off marker pens. Color of markerboards to be selected from manufacturer's standards and bronze trimmed.
- ⑤ RECESSED TRAY for storing chalk or marking pens and erasers shall be installed where indicated and shall be bronze color.

FURTHER INFORMATION. All dimensions shown in parentheses are millimeters. Moduflex Model 520 operable walls have 3 1/4" (83) thick welded steel panels for high performance demanding applications and are supplied with Autoseal™ clearance type bottom seal mechanisms that are actuated automatically by moving one panel pair against the other. Optional Manused™ available. Scale N.T.S.



Moduflex® SERIES 500

Paired Panels Model 520

TYPES OF CLOSURES AND PANEL STACKING

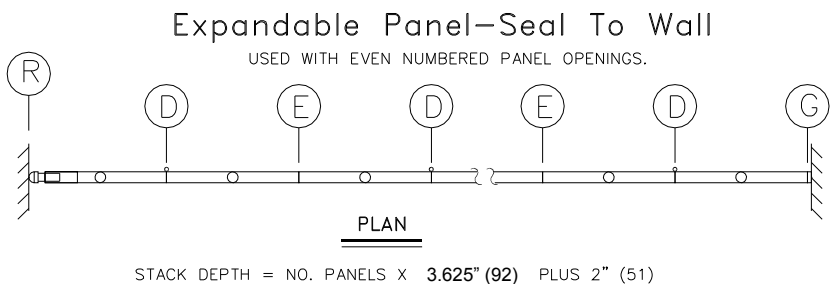
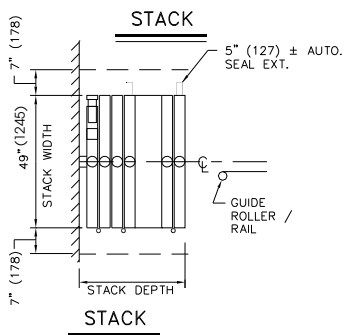
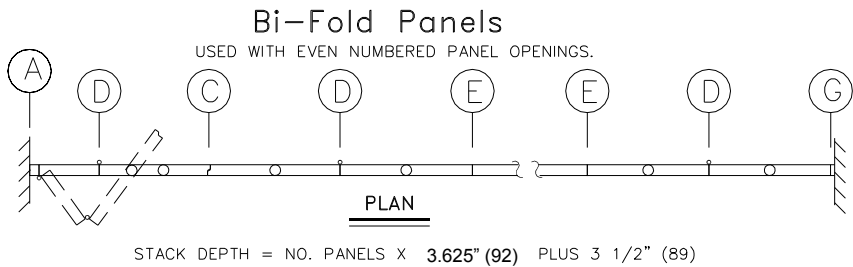
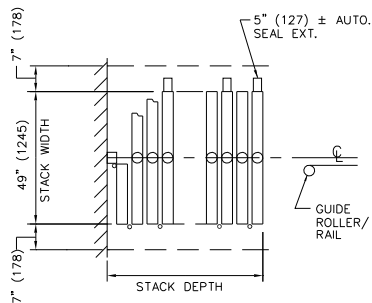
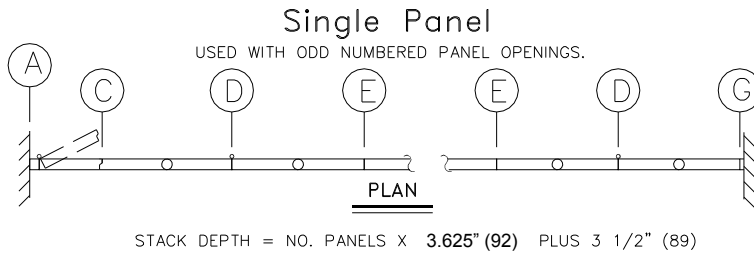
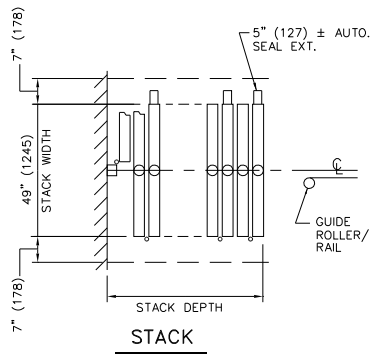



Moduflex® SERIES 500

Paired Panels Model 520

TYPES OF CLOSURES AND PANEL STACKING

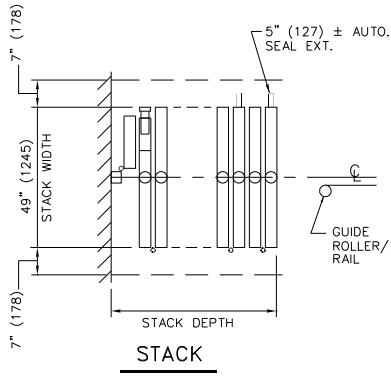

Single Panel With Expandable Panel

USED WITH ODD NUMBERED PANEL OPENINGS.

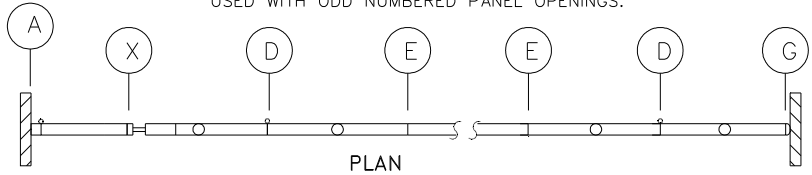

$$\text{STACK DEPTH} = \text{NO. PANELS} \times 3.625" (92) \text{ PLUS } 3 \frac{1}{2}" (89)$$

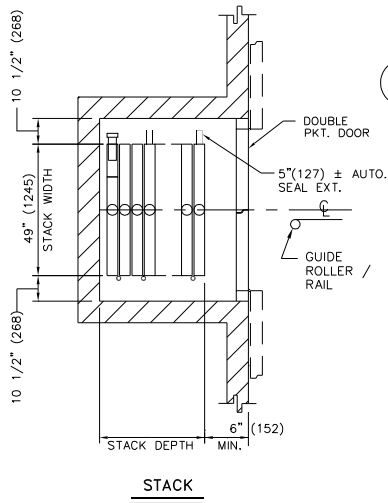

Expandable Panel – Seal To Pocket Doors

USED WITH EVEN NUMBERED PANEL OPENINGS.

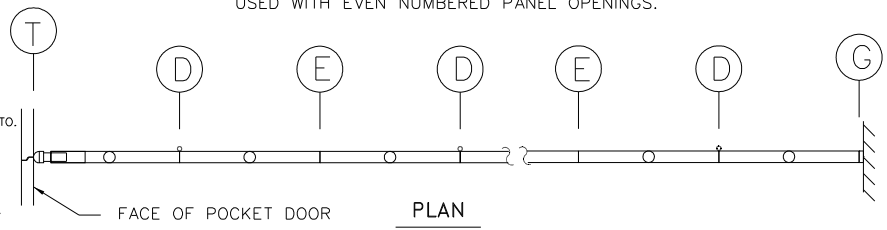

$$\text{STACK DEPTH} = \text{NO. PANELS} \times 3.625" (92)$$

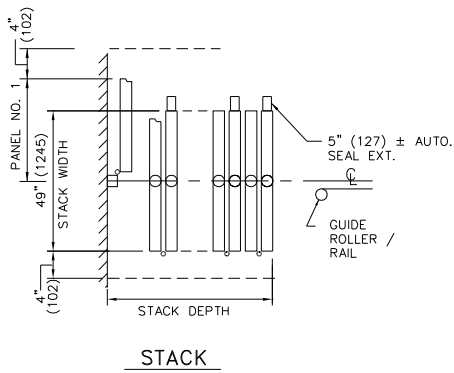

Communicating Panel

USED WITH ODD NUMBERED PANEL OPENINGS.

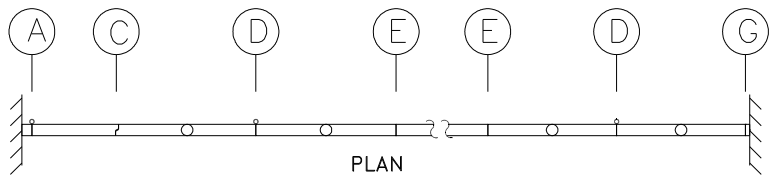

$$\text{STACK DEPTH} = \text{NO. PANELS} \times 3.625" (92) \text{ PLUS } 3 \frac{1}{2}" (89)$$

All dimensions shown in parenthesis are millimeters. Scale: N.T.S.



Moduflex® SERIES 500

Paired Panels Model 520

JAMBS AND PANEL INTERLOCKING DETAILS

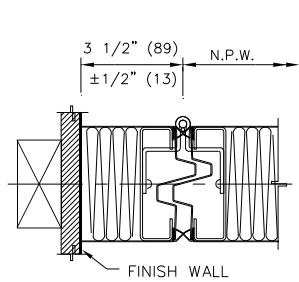

(A) ADJ. HINGED JAMB

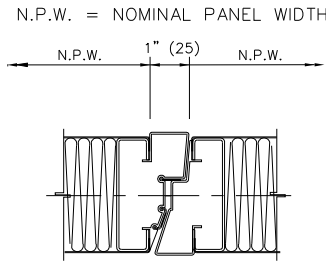

(C) CLOSURE DETAIL

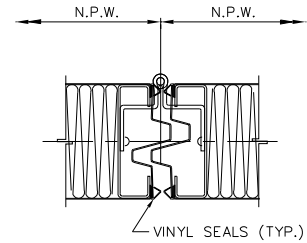

(D) HINGED INTERLOCK

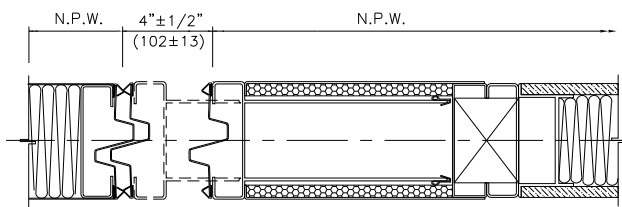

(X) EXPANDABLE PANEL WITH INTERLOCK

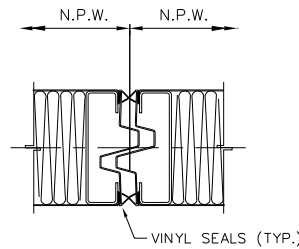

(E) INTERLOCK

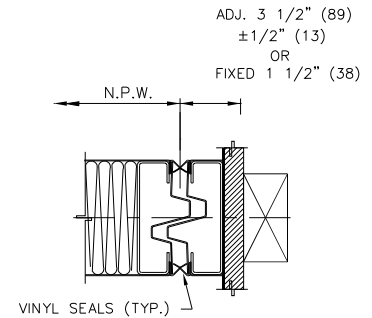

(G) LEAD JAMB

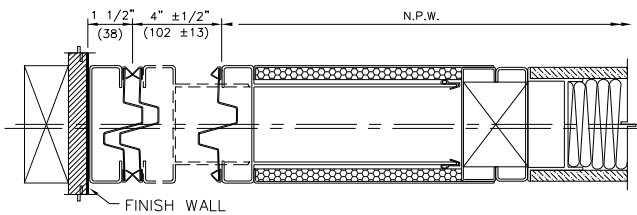

(R) EXPANDABLE PANEL WITH INTERLOCK AT JAMB

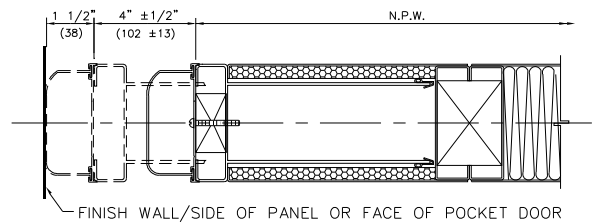

(T) EXPANDABLE PANEL WITH SOFT SEAL

All dimensions shown in parentheses are millimeters. Scale: N.T.S.



Moduflex® SERIES 500

Paired Panels Model 520

VERTICAL SECTION - HEAD DETAILS - TYPE 7/8 ALUMINUM TRACK

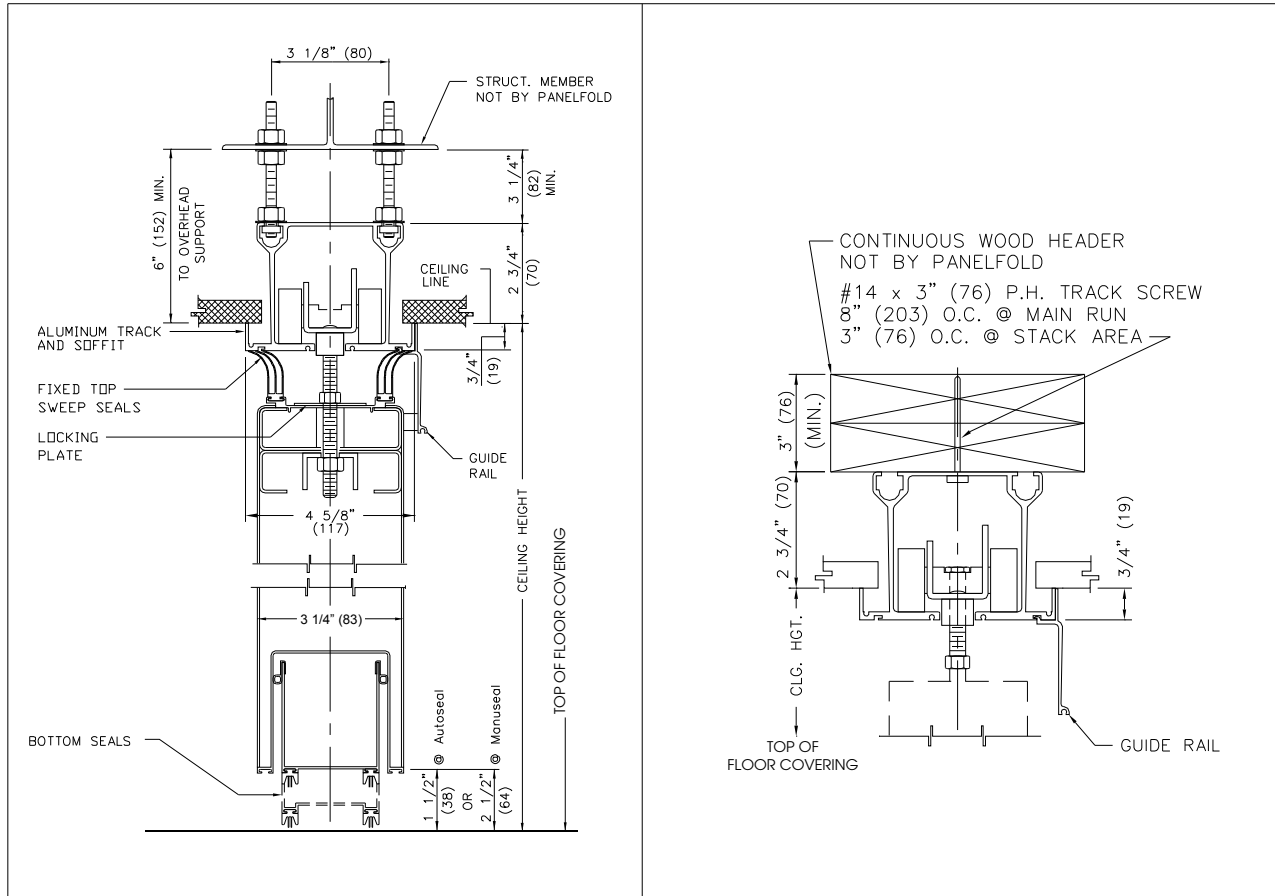

TYPE 7/8 TRACK
HANGER ROD SUSPENSION

TYPE 7/8 TRACK
DIRECT MOUNT

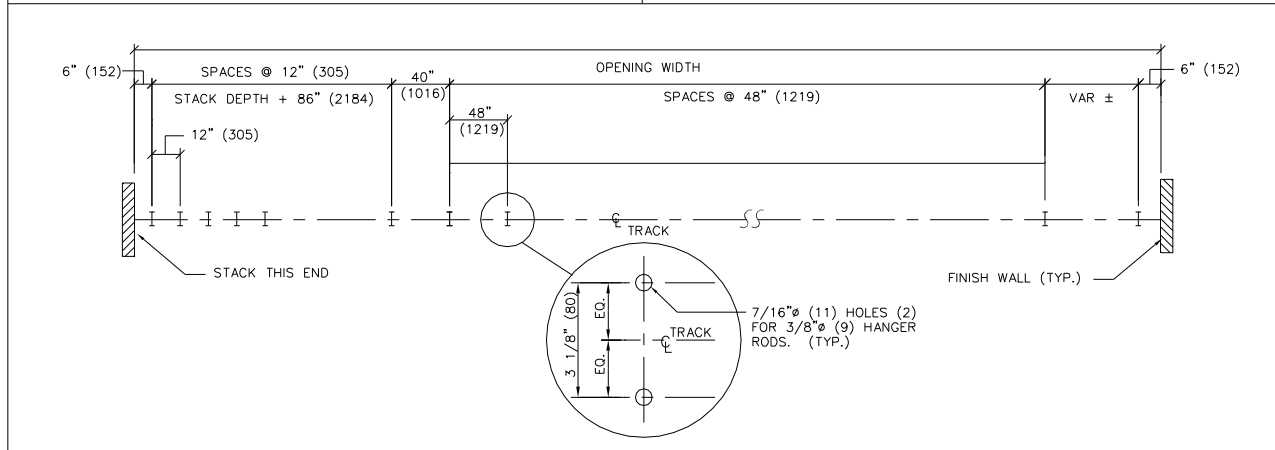

PUNCHING TEMPLATE

All dimensions shown in parentheses are millimeters. Scale: N.T.S.



Moduflex® SERIES 500

Paired Panels Model 520

VERTICAL SECTION - HEAD DETAILS - TYPE 5 STEEL TRACK

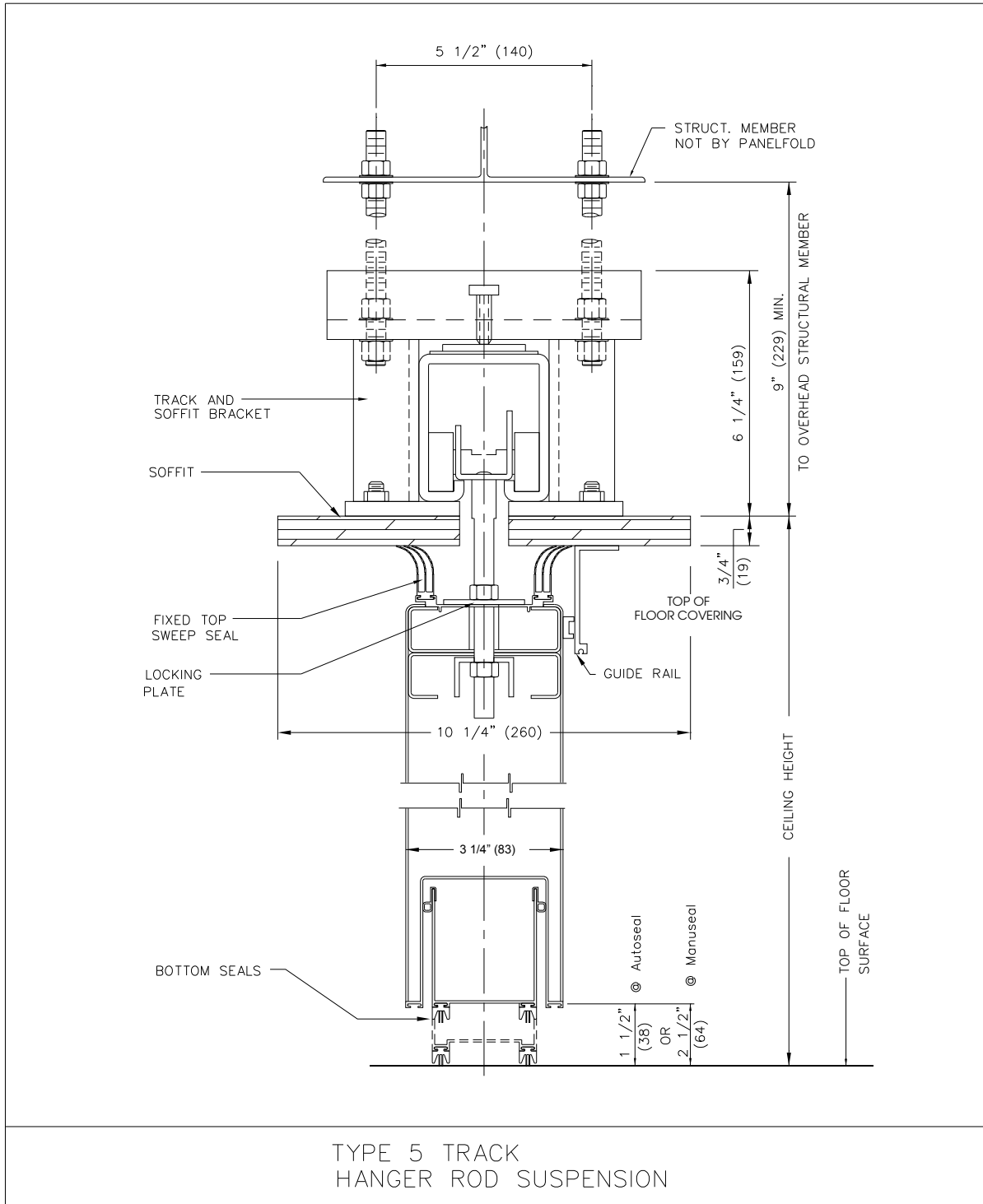

All dimensions shown in parenthesis are millimeters. Scale: N.T.S.



Moduflex® SERIES 500

Paired Panels Model 520

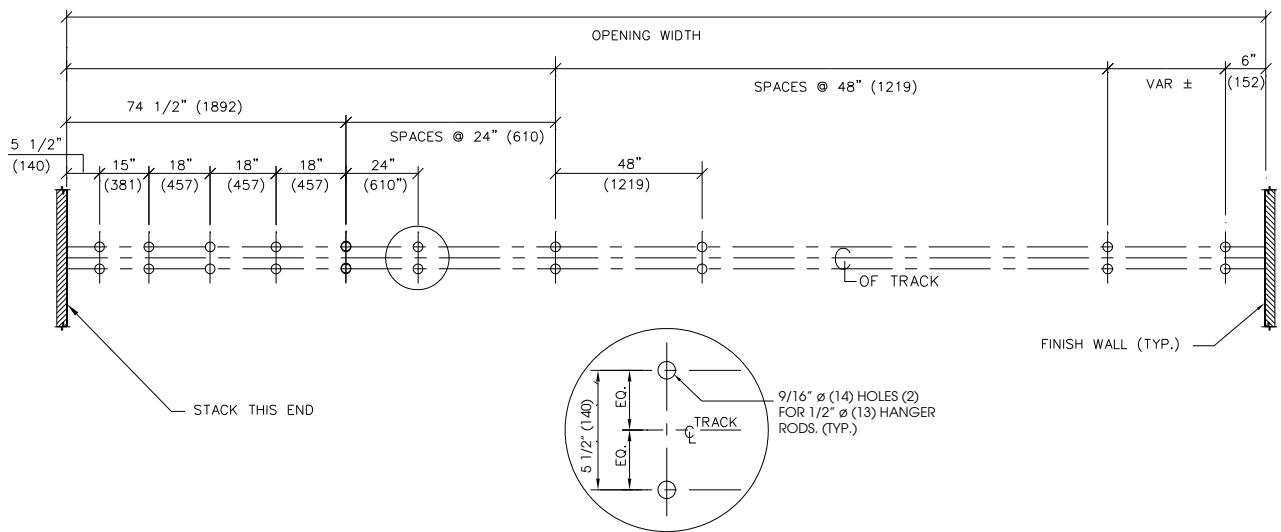

PUNCHING TEMPLATE
TYPE 5 STEEL TRACK

Moduflex® SERIES 500

Paired Panels Model 520

PRODUCT SPECIFICATIONS: SECTION 10650 - OPERABLE WALLS

PART 1 GENERAL

(See Project Guide Specifications for Scope, Related Work, References, Submittals, Product Delivery and Acceptable Manufacturers paragraphs.)

PART 2 PRODUCTS

- 2.1 OPERABLE WALLS** shall be manufactured by Panelfold, Inc., Miami, Florida, U.S.A. and installed by an authorized representative of the manufacturer in openings prepared by others to Moduflex® Series 500 requirements.
- 2.2 OPERATION** shall consist of a series of manually operated flat panels, top supported. Top and bottom seals shall be as specified in paragraph 2.8.
- 2.3 PANEL CONFIGURATION** shall be as follows for areas indicated on the plans:
- 2.3.1 MODEL 520 shall be comprised of panels hinged in pairs, and center stacking (located in room(s)).
- 2.3.2 Final closure shall be effected by (specify: Single or Bi-Fold Panels; Expandable Panels; or Jamb-Hinged Communicating Panels).
- 2.4 PANELS** shall be one-piece 3 1/4" (83) thick all-steel construction. Continuous steel panel faces shall be invisibly welded to minimum 16 gauge (1.59) one-piece steel frames. Horizontal or vertical spliced frames or faces shall not be permitted. Interlocking vertical panel edges and operable seals shall be made of steel.
- The vertical edges of the panels shall not require trim thus minimizing the appearance of the vertical joining of the Sheer-Look® panels.
- 2.5 PANELS** shall be factory surfaced with one of the following (colors to be selected from manufacturer's standards):
- 2.5.1 Manufacturer's standard vinyl, Class A flame spread (specify Type I; or Type II).
- 2.5.2 Manufacturer's standard Ribtex® Basic, vertical-rib wall carpeting, Class A.
- 2.5.3 Manufacturer's Woventex® panel fabric, Class A, acrylic latex backed.
- 2.5.4 Maharam Tekwall panel fabric, Class A, acrylic backed.
- 2.5.5 Customer's Own Material to be factory applied (subject to approval by the manufacturer for suitability to standard manufacturing processes and equipment).
- 2.5.6 Coated steel panel faces for field surfacing by others.
- 2.6 HANGING WEIGHT** of panels shall not exceed 9 lbs./ff² (44 Kg/m²).
- 2.7 ACOUSTICAL RATING** as tested by an independent acoustical laboratory in accordance with

ASTM E90-81 test procedure in a full scale 14' 0" (4267) by 9'3" (2819) opening shall be (specify: STC 52 or STC 50).

2.9 SOUND SEALS shall be as follows:

- 2.9.1 Vertical seals between panels shall consist of deep nesting, universal interlocking ESP bronze steel astragals incorporating continuous, vinyl acoustical seals. Vertical astragal vinyl seals shall be installed on the outboard edges of the panel skins in a double row with an acoustical labyrinth.
- 2.9.2 Horizontal TOP seals shall be (specify: continuous contact extruded vinyl shapes; clearance type, manually actuated; or clearance type, automatically actuated).
- 2.9.3 Horizontal BOTTOM seals shall be (specify: 1 1/2" (38) clearance-type automatically actuated by the movement of one panel-pair against the other; or 2 1/2" (64), clearance-type manually actuated at waist height on panel edges). Downward pressure of all clearance-type seal mechanisms shall assure an acoustical seal and resist panel movement.

2.10 SUSPENSION SYSTEM shall be heavy duty aluminum Type 7/8 or steel Type 5 track. Track shall be supported by adjustable steel hanger rods; or direct mount @ type 7/8 only. Panels shall be supported by trolley assemblies of radial type steel or nylon tired or carbon fiber fill tired, steel ball-bearing wheels. Trolleys shall be attached to the panels with adjustable steel pendant bolts with locks to prevent panel misalignment.

2.11 PANELS that are hinged together shall be hinged with manufacturer's standard butt-type hinges.

2.13 POCKET DOORS where indicated on the plans shall be manufactured of the same materials as the panels. Hinges shall be standard butt-type.

PART 3 EXECUTION

(See Project Guide Specifications for Execution, Installation, Cleaning and Demonstration paragraphs).

NOTE: The ASTM - 84 procedure Class A flame spread and other test results referenced herein are for comparison purposes only and are not intended to reflect hazards presented by this or any other materials under actual fire conditions.

For further information, or additional technical information, contact your Panelfold distributor.

Panelfold®

FOLDING DOORS • ACOUSTICAL FOLDING PARTITIONS • ACOUSTICAL PANELS
 OPERABLE WALLS • RELOCATABLE WALLS

Panelfold, Inc. P.O. Box 680130, Miami, Florida 33168
 (305) 688-3501 • FAX: (305) 688-0185
 Internet: www.panelfold.com • E-mail: sales@panelfold.com